

LUMASOL

INSTALLATION GUIDE

FLUSH MOUNT
NON-PENETRATIVE ROOF MOUNTING SYSTEMS

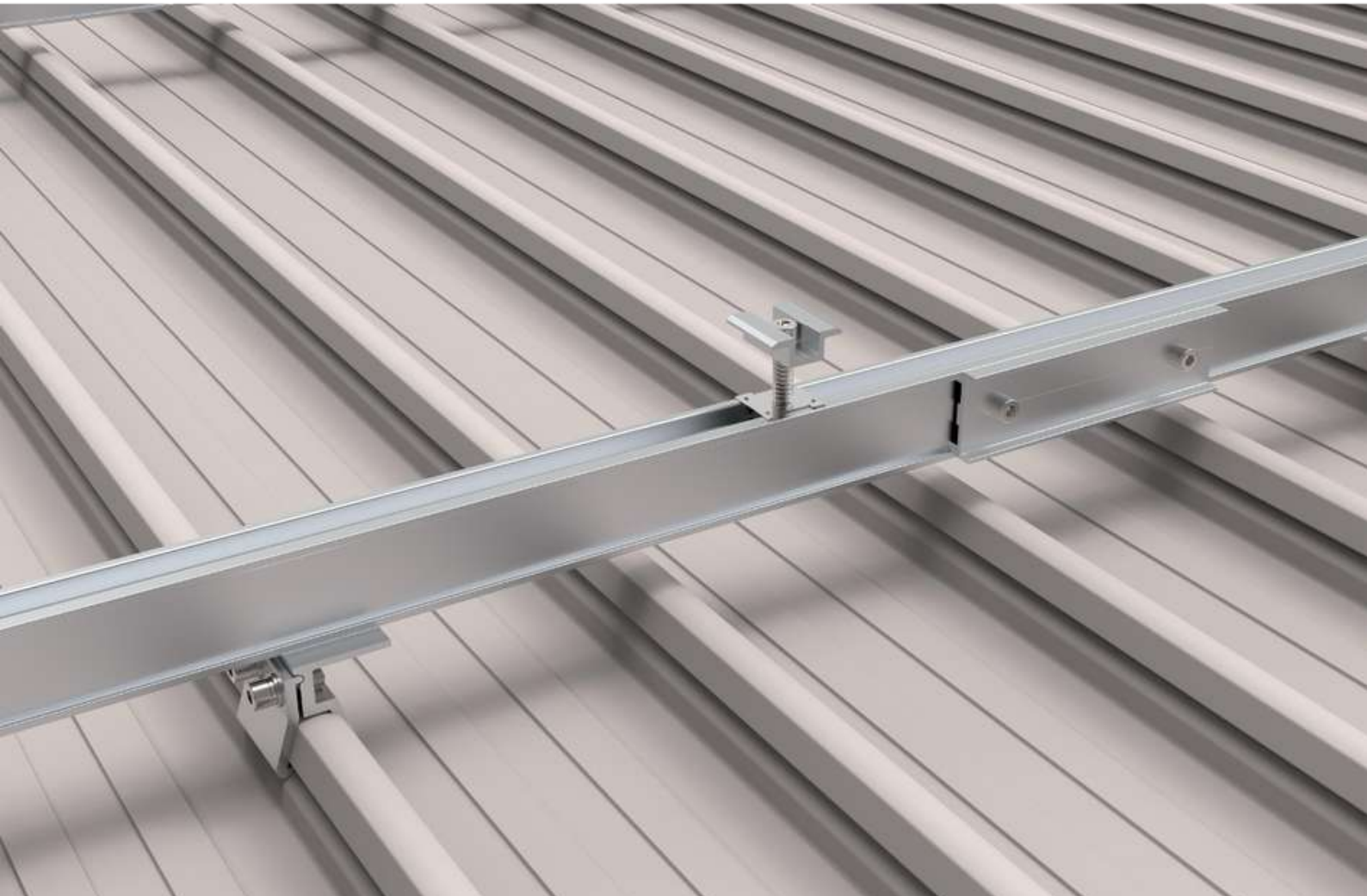



Contents

1. Introduction
2. Planning
3. Tools and components
4. System Overview
5. Installation Instructions
6. Metal Roof Clamp Installation
7. Rail Installation
8. Mini Rail Installation
9. Solar Panel Installation
10. Grounding Lug Installation





Introduction

The Lumasol flush mount system, with non-penetrative metal roof clamps, offers a cost effective and time efficient installation solution for metal roofs.

Please review this manual thoroughly before installing your solar system.

The installer is solely responsible for:

- Complying with all applicable local or national building codes, including any updates that may supersede this manual.
- Ensuring that The Flush Mount with Non- penetrative Metal Roof Clamp System and other products are appropriate for the installation and the installation environment.
- Using only the correct Lumasol components for the mounting structure installation (substitution of parts or mixing products from different brands may void the warranty)
- Recycling: Recycle according to the local regulation.
- Ensuring that there are no less than two professionals working on the panel installation.
- Ensuring the installation of related electrical equipment is performed by licensed electricians.
- Ensuring safe installation of all electrical aspects of the PV array. This includes adequate earth bonding of the PV array and the FLUSH-MOUNT SYSTEM components.
- Ensuring that the roof, its rafters/purlins, connections, and other structural support members can support the array under building live load conditions.
- Verifying the compatibility of the installation considering prevent metal electrochemical corrosion between dissimilar metals. This may occur between structures and the building, between structures, fasteners, and PV modules.
- Verifying atmospheric corrosivity zones of the installation site or consult with local construction business to determine appropriate products and installations.
- Removal: Reverse installation process.

Product Warranty:

Please refer to the Lumasol product warranty and register your product warranty on our website at <https://lumasol.co.za/warranty-registration/> or request information from our team, sales@lumasol.co.za / admin@lumasol.co.za.



Planning

Determine the type of metal roof sheeting.

To determine the type of metal roof sheeting, check the manufacturers label located underneath the roofing sheet. Alternatively, you can contact the builder or refer to the building plans for the exact roofing sheet type.

Notes:

- 1.) Use of the Lumasol Metal Roof Clamp is accredited only on the roof sheet types listed below.
- 2.) If the roof sheet type (brand and model) cannot be identified or is not in the below list, it is recommended to conduct an on-site pull-out capacity test.
- 3.) Lumasol Metal Roof Brackets can be in direct contact with most roof sheets without the use of material in-between the bracket and roof sheet. Please verify the roof sheet material and its compatibility with the mounting bracket (material: anodized aluminum) from the roof sheet manufacturer.

Saflok 700

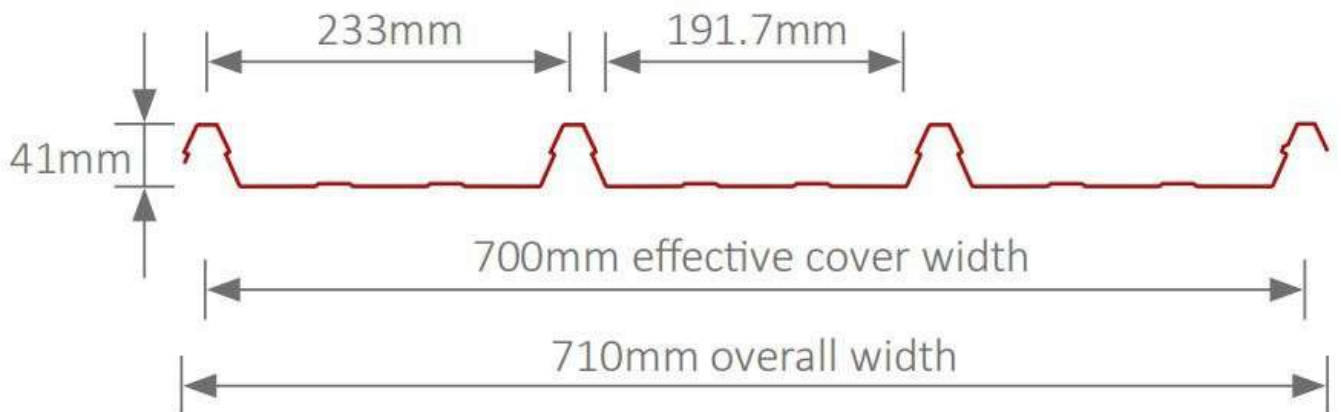

Saflok 410



Lysaght Kliplock 305 (Standing Seam)

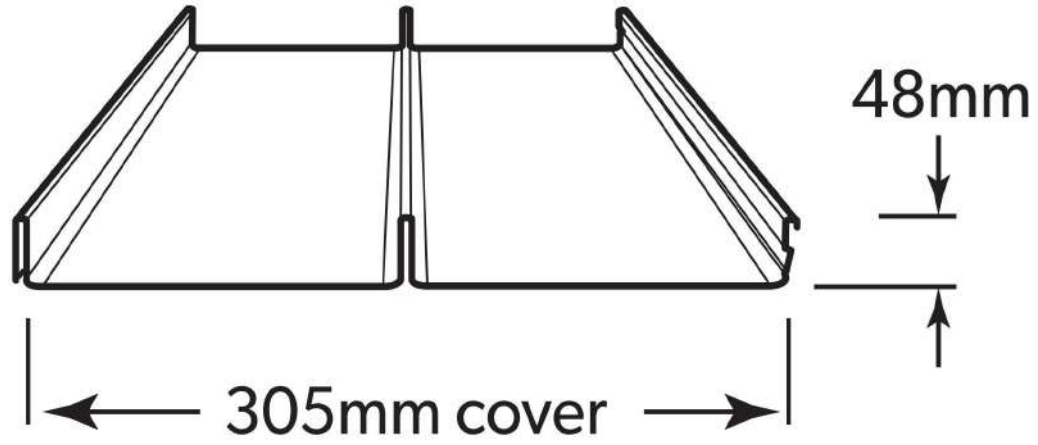

Determine the Region Definition & Terrain Category

SANS 10160-3:2019
Edition 2.1

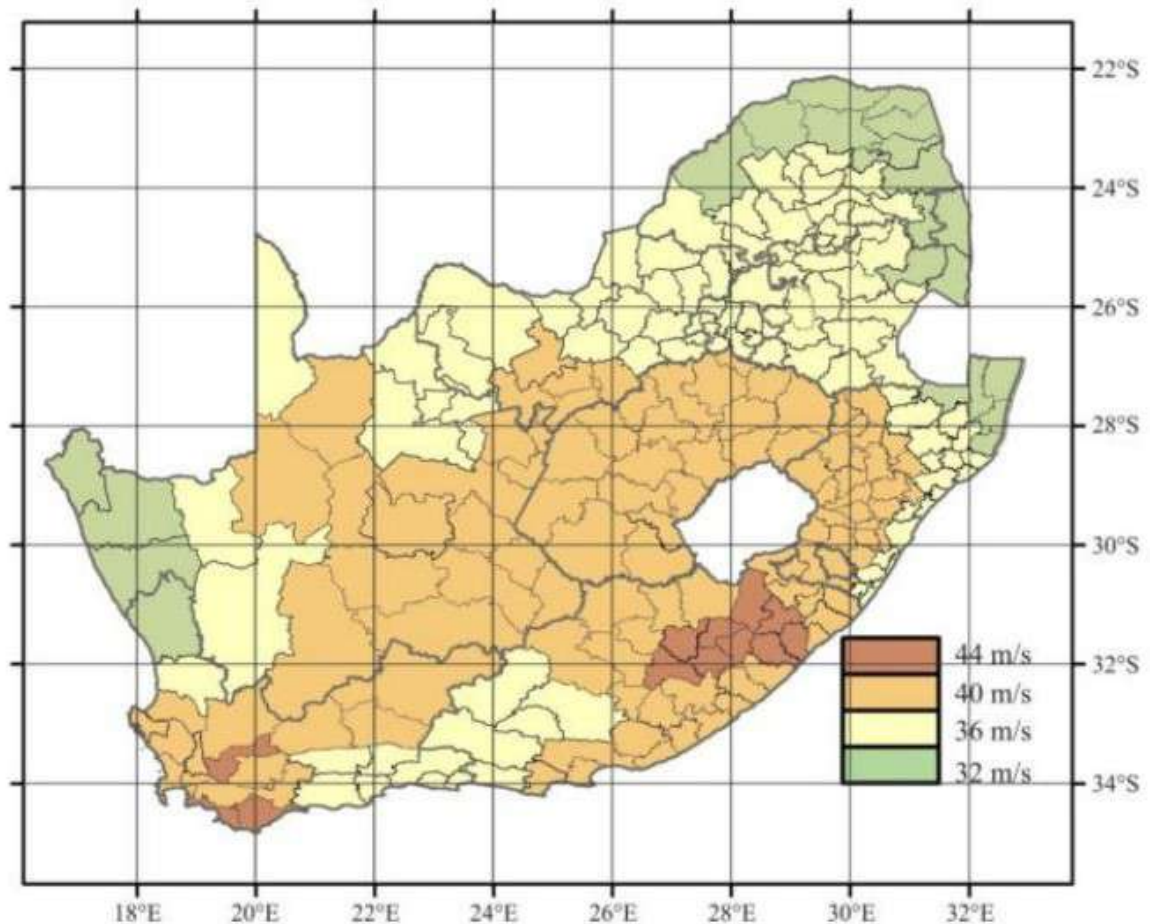

Doc.697a



NOTE 1 This map results from comprehensive statistical research. (Strong winds in South Africa: Part 1 and Part 2) and is based on 3 second gust wind speed. Tabularised information, per municipality, is provided in table A.1 of annex A.

NOTE 2 This map should be used in combination with the partial factor for wind loading as stipulated in SANS 10160-1. For structures particularly sensitive to wind action, detailed investigation on an appropriate partial action factor may be required.

Figure 1 — Map of the fundamental value of the basic wind speed, $v_{b,0}$

- Region A which indicates a Regional Wind Velocity of 32 m/s with wind average recurrence of 50 years.
- Region B which indicates a Regional Wind Velocity of 36 m/s with wind average recurrence of 50 years.
- Region C which indicates a Regional Wind Velocity of 40 m/s with wind average recurrence of 50 years.
- Region D which indicates a Regional Wind Velocity of 44 m/s with wind average recurrence of 50 years.

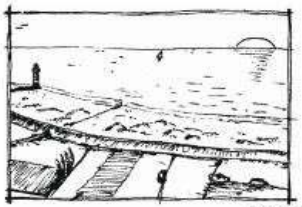
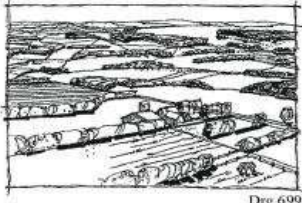
Table 2 — Terrain categories

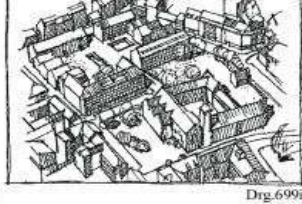
1	2	3
Category	Description	Illustration
A	Flat horizontal terrain with negligible vegetation and without any obstacles (for example coastal areas exposed to open sea or large lakes)	 Drg.699j
B	Area with low vegetation such as grass and isolated obstacles (for example trees and buildings) with separations of at least 20 obstacle heights	 Drg.699ia
C	Area with regular cover of vegetation or buildings or with isolated obstacles with separations of maximum 20 obstacle heights (such as villages, suburban terrain and permanent forest)	 Drg.699ib
D	Area in which at least 15 % of the surface is covered with buildings and their average height exceeds 15 m	 Drg.699ic

NOTE 1 A certain amount of a reduction in loading for category D can be obtained (see 7.3.5) by using a procedure described in A.5, which takes into account the vertical displacement of the peak wind pressure profile, within an environment with closely spaced obstructions.

Lumasol Rooftop Solar mounting systems are assessed for terrain category C. If your installation site is not within a “category C” location, adjust the interface spacing by the relevant factor below:

- Category A: 90%
- Category B: 95%
- Category D: 106%

Verify Atmospheric Corrosivity Zone of Installation Site

Refer to ISO 9223:2012 - **Corrosion of Metals and Alloys - Corrosivity of Atmospheres - Classification, Determination, and Estimation** to verify the corrosivity category of the installation site. This will help determine the appropriate products and interface spacing. When standard products are installed in high-corrosivity zones such as C4 or C5, a reduction factor must be applied to the interface spacing. For installations in ISO corrosivity category C4, reduce the interface spacing by 5%

Table C.1 — Description of typical atmospheric environments related to the estimation of corrosivity categories

Corrosivity category ^a	Corrosivity	Typical environments — Examples ^b	
		Indoor	Outdoor
C1	Very low	Heated spaces with low relative humidity and insignificant pollution, e.g. offices, schools, museums	Dry or cold zone, atmospheric environment with very low pollution and time of wetness, e.g. certain deserts, Central Arctic/Antarctica
C2	Low	Unheated spaces with varying temperature and relative humidity. Low frequency of condensation and low pollution, e.g. storage, sport halls	Temperate zone, atmospheric environment with low pollution ($SO_2 < 5 \mu g/m^3$), e.g. rural areas, small towns Dry or cold zone, atmospheric environment with short time of wetness, e.g. deserts, subarctic areas
C3	Medium	Spaces with moderate frequency of condensation and moderate pollution from production process, e.g. food-processing plants, laundries, breweries, dairies	Temperate zone, atmospheric environment with medium pollution ($SO_2: 5 \mu g/m^3$ to $30 \mu g/m^3$) or some effect of chlorides, e.g. urban areas, coastal areas with low deposition of chlorides Subtropical and tropical zone, atmosphere with low pollution
C4	High	Spaces with high frequency of condensation and high pollution from production process, e.g. industrial processing plants, swimming pools	Temperate zone, atmospheric environment with high pollution ($SO_2: 30 \mu g/m^3$ to $90 \mu g/m^3$) or substantial effect of chlorides, e.g. polluted urban areas, industrial areas, coastal areas without spray of salt water or, exposure to strong effect of de-icing salts Subtropical and tropical zone, atmosphere with medium pollution
C5	Very high	Spaces with very high frequency of condensation and/or with high pollution from production process, e.g. mines, caverns for industrial purposes, unventilated sheds in subtropical and tropical zones	Temperate and subtropical zone, atmospheric environment with very high pollution ($SO_2: 90 \mu g/m^3$ to $250 \mu g/m^3$) and/or significant effect of chlorides, e.g. industrial areas, coastal areas, sheltered positions on coastline

Determine the Height of the Installation Site:

This document provides adequate guidance for installing the Flush Mount with Non-penetrative Metal Roof Clamp System at heights up to 20 meters. For installations above 20 meters, a project-specific engineering certificate must be obtained to ensure proper support.

Determine Roof Slope:

The Flush Mount with Non-penetrative Metal Roof Clamp System is suitable for roof slopes up to 30°. Ensure that the slope of the installation site roof is within the 0° to 30° range.

Determine the Installation Area:

The roof installation should be positioned directly on top of the purlins, with a maximum tolerance of 150mm. Refer to the sketch below for further details.

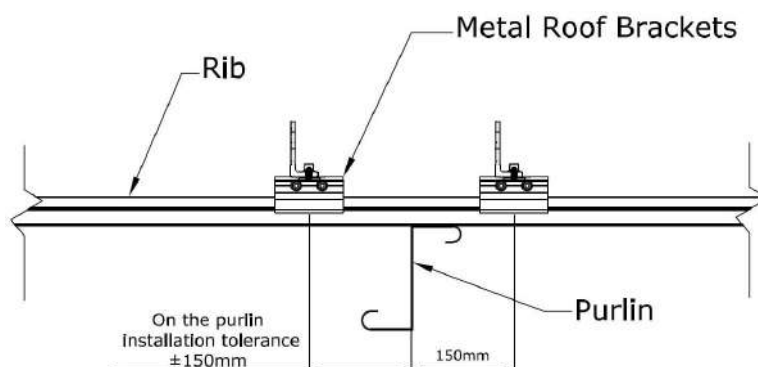

Determine the Maximum Rail Support Spacing

The conditions for achieving a maximum installation interface spacing of 1.5m with the Lumasol Flush Mount with Non-penetrative Metal Roof Clamp System are as follows:

1. The roof height $\leq 20\text{m}$
2. The roof tilt angle ≤ 10 degrees
3. The roof zone is located in zone H

Any installation that exceeds the restrictions above requires that the installation interface spacing is reduced accordingly.

Verify Maximum Rail End Overhang

Rail end overhang is the distance from the last interface to the end of the panel. The maximum allowable rail end overhang is 40% of the installed spacing of the last interface. For instance, if the maximum interface spacing as per the engineering certificate is 1500mm, and the actual installed spacing of the last interface is 1500mm, the maximum allowable rail end overhang would be 600mm. Refer to the picture below for clarification.



Determine the Clamping Zone of the PV Modules

Please refer to the installation manual of the PV module manufacturer.





Tools and Components

Tools



Screwdriver



Drill Bits for M8 bolts



Torque spanner



5m Tape



Marker pen



String

Components



LMS-PRO-RAILH
PV Mounting ProRailH
3150mm, 4150mm, 5150mm



LMS-RAILH-SP-KIT
Splice Kit for ProRailH - L175



LMS-SS-KIT
Standing Seam Multi Clamp Kit



LMS-EC30-35-KIT-BP
End Clamp 30 & 35 Kit
(Bonding Pin)



LMS-IC30-35-KIT-BP
Inter Clamp 30 & 35 Kit
(Bonding Pins)



LMS-KL1-KIT
Saflok 410/700 Cleat



LMS-KL1-MR-KIT
Saflok 410/700 Mini-Rail
Clamp Kit



LMS-RN-M8x20-KIT
Rail Nut Kit M8x20



LMS-EGL-KIT
Grounding Lug



System overview

1. End Clamp 2. Mid Clamp 3. Rail 4. Metal Roof Clamp 5. Rail Joiner 6. Rail Nut

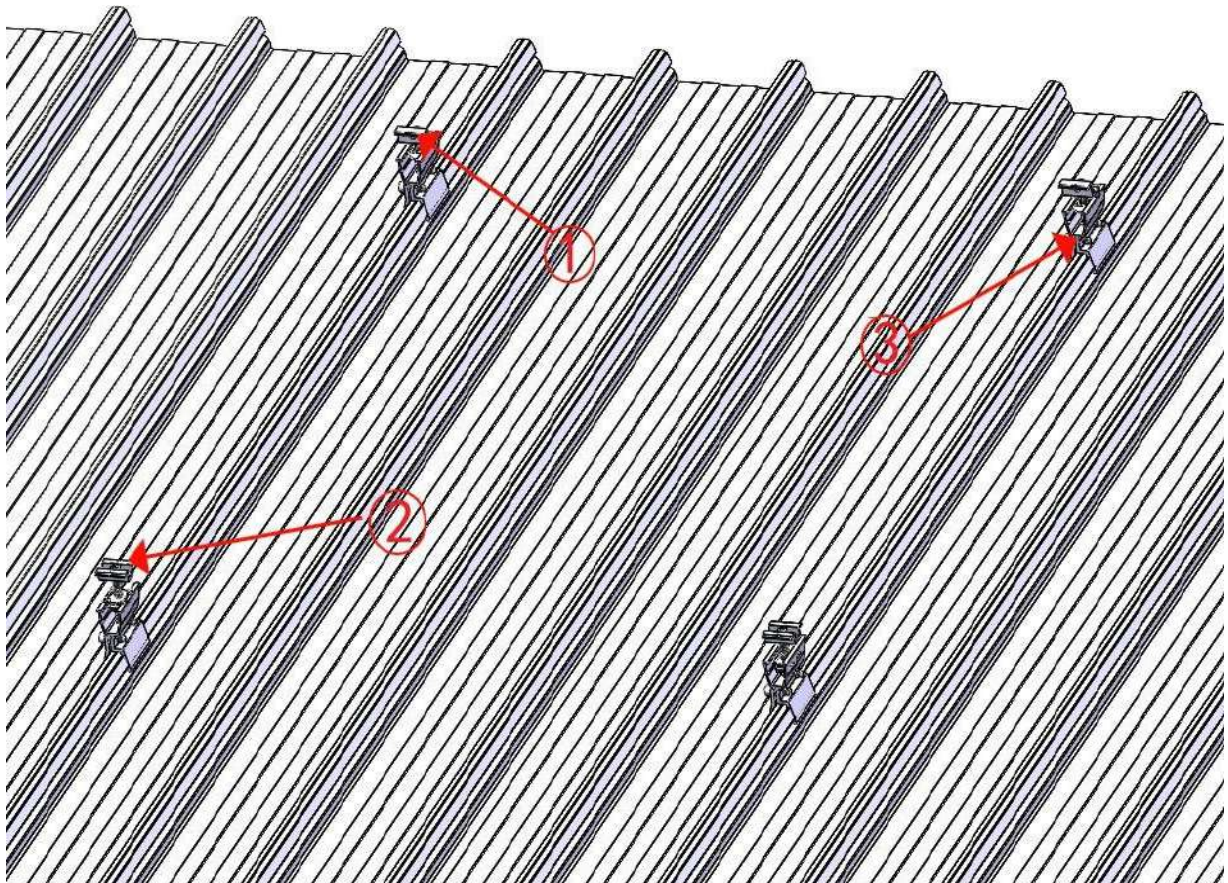
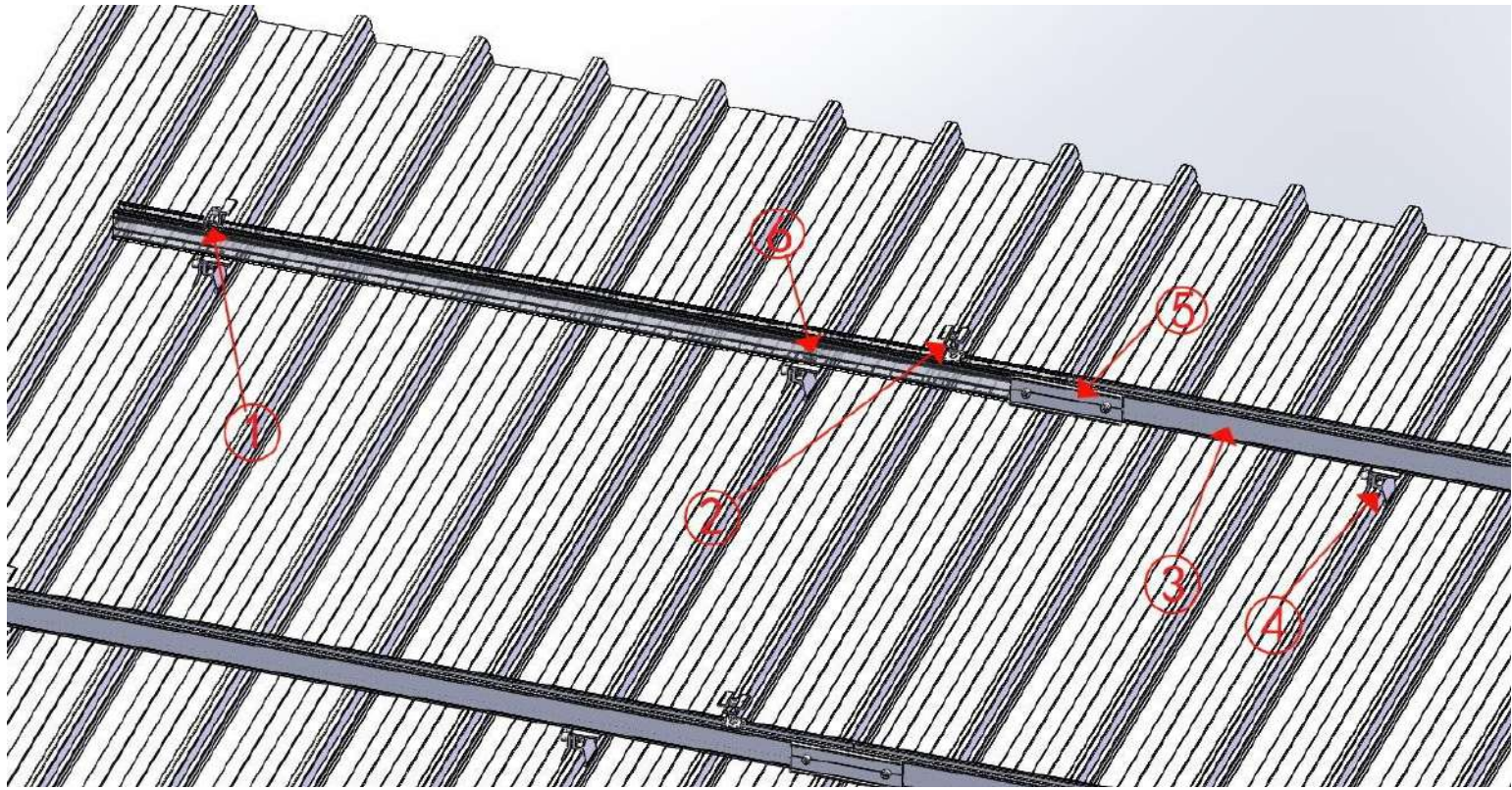

Precautions During Stainless Steel Fastener Installation

Improper installation can lead to the seizing (galling) of nuts and bolts. Follow the steps below to reduce the risk of thread galling when assembling stainless steel nuts and bolts.

General Installation Instructions

- Apply force to fasteners in the direction of the thread.
- Apply force evenly to achieve the required torque.
- Use professional tools for better control and accuracy.
- If desired, to prevent galling or seizing of threads, apply a lubricant (such as grease or oil).

Safe Torques

Refer to the safe torque values provided in this guide and the accompanying figures. If power tools are necessary, use them at low speeds. High-speed or impact drivers increase the likelihood of galling. If galling occurs and fasteners need to be cut, ensure there is no load on the fastener before cutting. Take care not to damage anodized or galvanized surfaces.

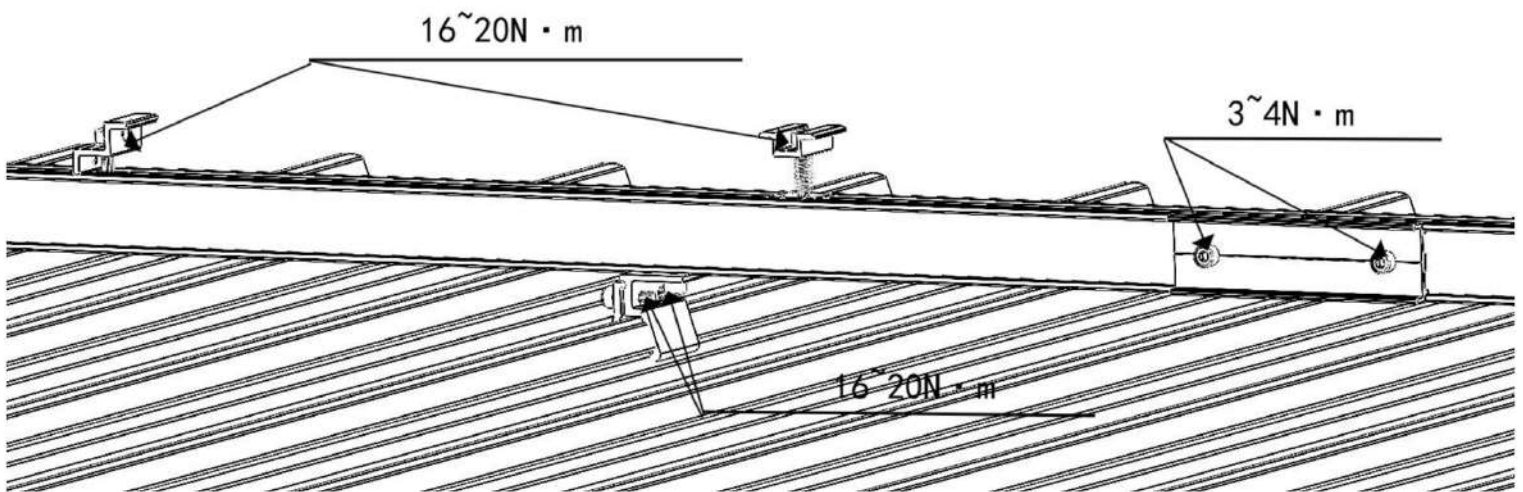

Item	Panel Clamps	Rail Joiner	Roof Clamp
Product code	LMS-EC30-35-KIT-BP LMS-IC30-35-KIT-BP	LMS-RAILH-SP-KIT	LMS-KL1-KIT LMS-KL1-MR-KIT LMS-SS-KIT
Correct Torque (N.m)	16-20	3-4	16-20



Installation Instructions

All drawings and dimensions in this Installation Guide are for generic reference only. The Flush Mount with Non-penetrative Metal Roof Clamp System must be tailored to meet the specific conditions of each project and documented in a construction drawing.

The installation process outlined in this guide remains consistent, even if component sizes vary.

For any on-site modifications or alterations, please submit marked-up drawings or sketches to Lumasol for review, comment, and approval prior to making changes.

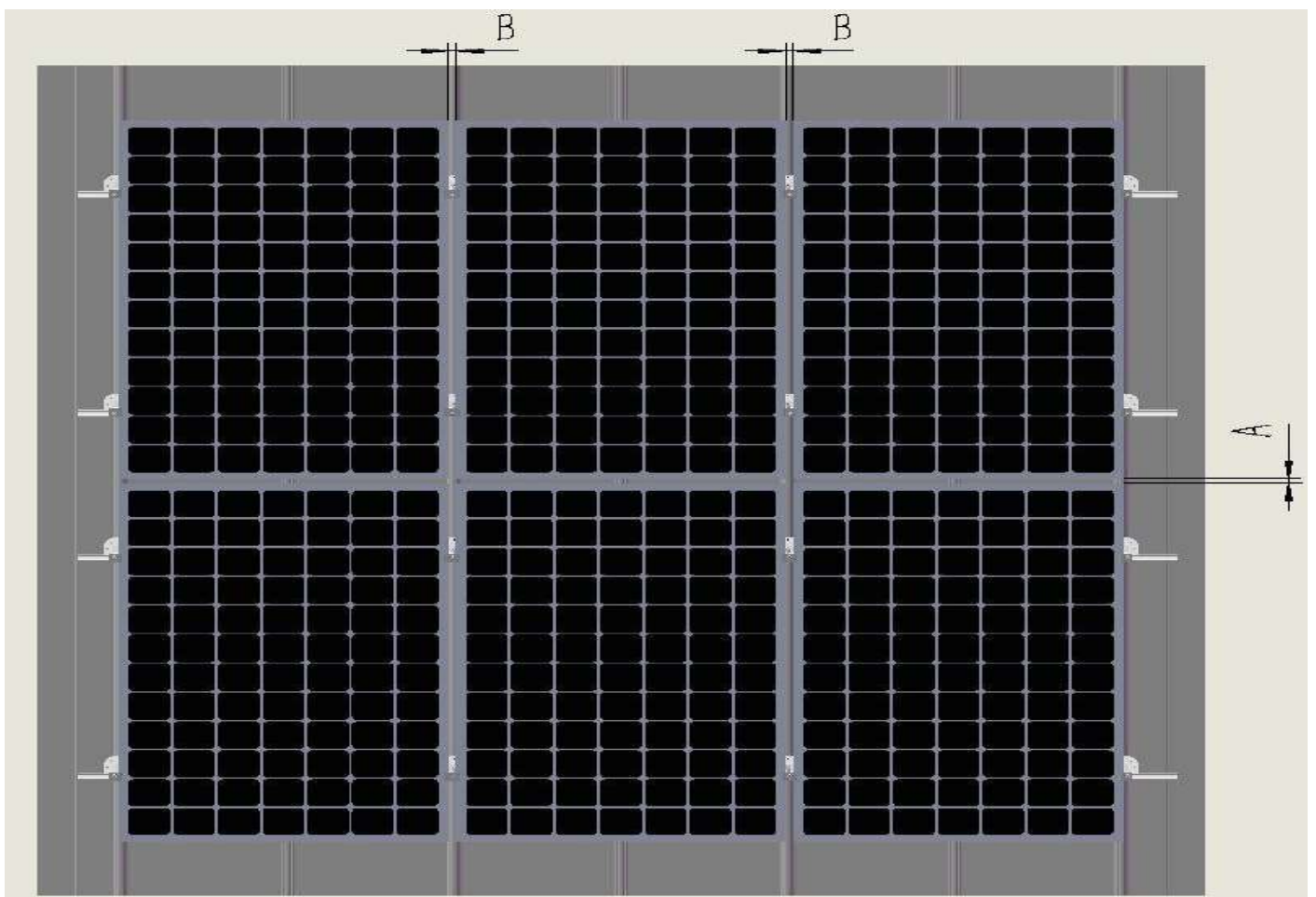

- Determine the number of modules in the vertical direction by using the module height, allowing for at least 18mm (A) spacing between modules (check the solar module manufacturer's installation manual).
- Determine the number of modules in the horizontal direction using module width + width "B". Width B depends on the mid clamps used. Ensure the module frame sits flush against the mid clamp.
- Assess the horizontal spacing of the Metal Roof Clamps.
- Assess the vertical spacing of the Roof Brackets, which should be approximately 1/2 to 3/4 of the module height.

Always check the installation manual of the PV-Module you use to determine the allowed fixing points on the module frame.

Metal Roof Clamp Installation:

Position the first Metal Roof Clamp according to the installation plan or drawing, and lightly fasten it to the rib of the metal roof.

The recommended torque for the M8 bolts is 16-20 N·m. Ensure the Metal Roof Clamp is installed in a straight line, as illustrated in the figure below.

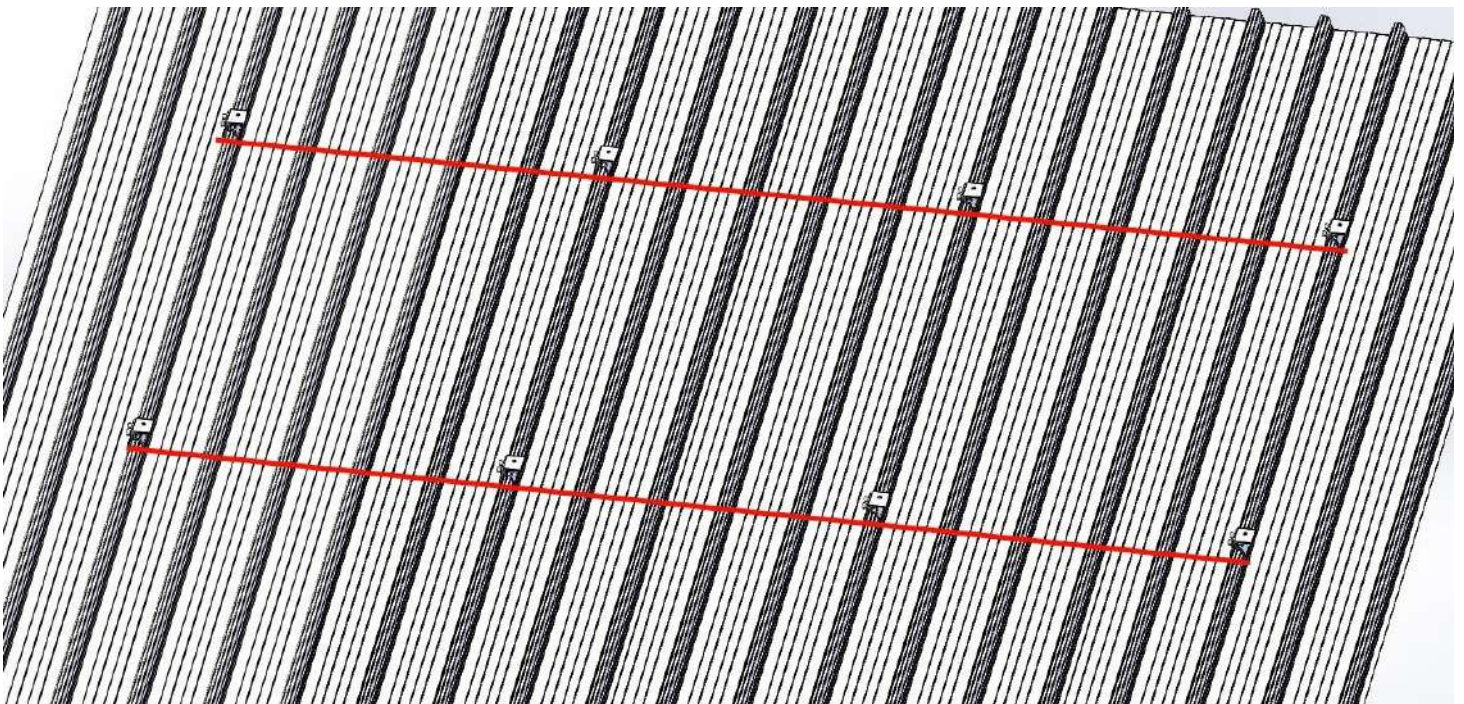
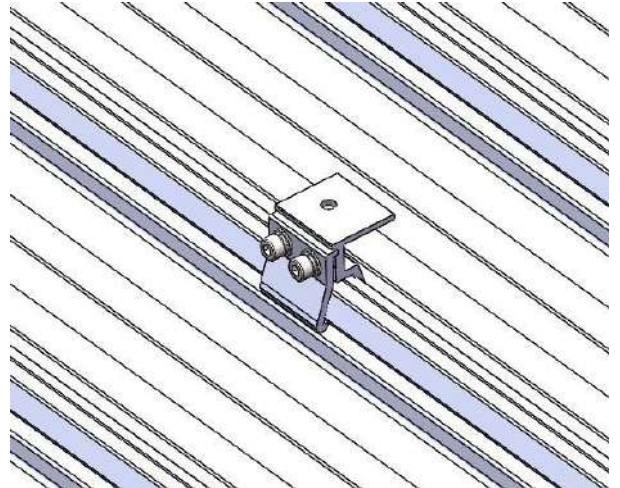

Notes:

The conditions for achieving a 1.5m interface spacing are a maximum roof height of 20m and a maximum roof tilt angle of 10 degrees.

It is recommended that all solar panels and mounting structures are installed within Zone H.

*e is the minimum value of

- 2 x Roof Height
- Roof width
- Roof length

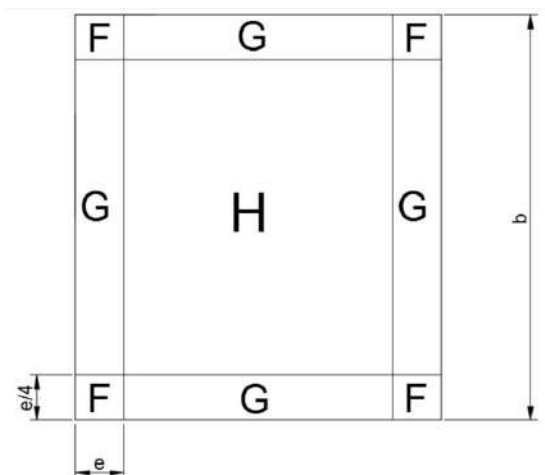

Rail Installation:

Determine the rail's mounting position according to the installation plan.

To connect two rails, slide half of the splice into the corresponding groove on both rails, as seen in the images below. When the splice bolts are tightened, they pierce the anodized film on the rail's surface, ensuring both a secure connection and electrical conductivity between the two rails.

Rail splice connectors must not be installed at support points or at the mid-span between two adjacent supports. It is recommended to position the splice at $1/4$ span points from the supports. The recommended torque for fastening the splice bolts is 16-20 N·m.

Ensure the rail is properly aligned when attaching it to the roof clamp, as shown in the figure below, (U-channel facing upwards). Tighten the M8 bolts between the rail and the Metal Roof Clamp to a recommended torque of 16-20 N·m.

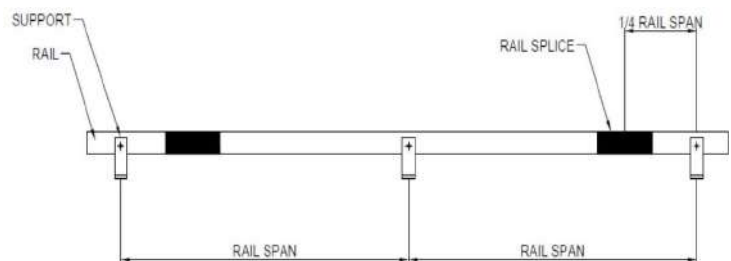
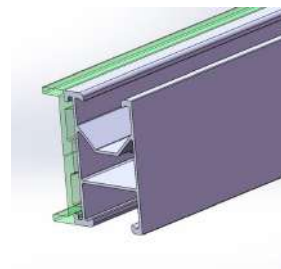
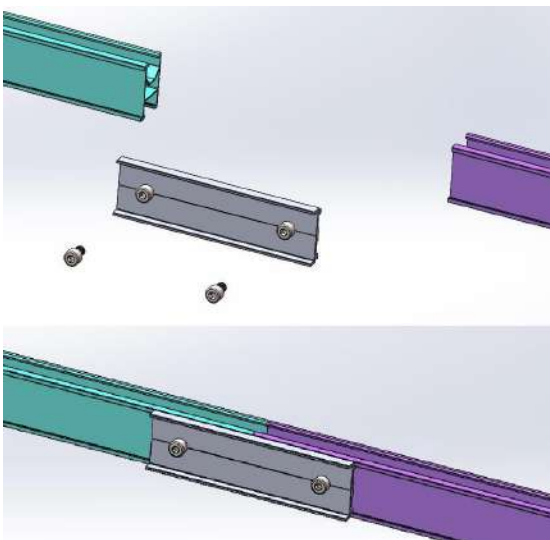

Notes:

- Ensure the rail is properly aligned when securing it to the roof clamp. The recommended torque for tightening the M8 bolts between the rail and the Roof Clamp is 16-20 N·m.
- To maintain the strength of both the rail and splice, each rail must be supported by at least two interfaces, as shown in the figures above.

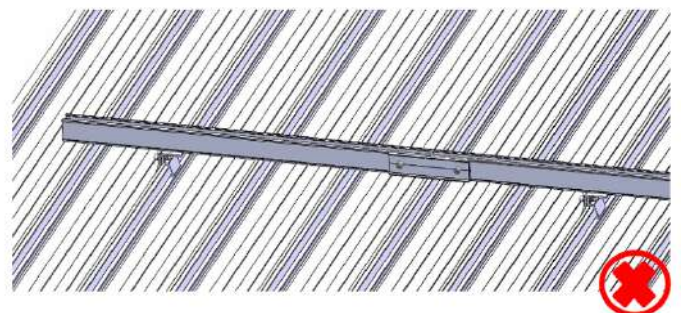
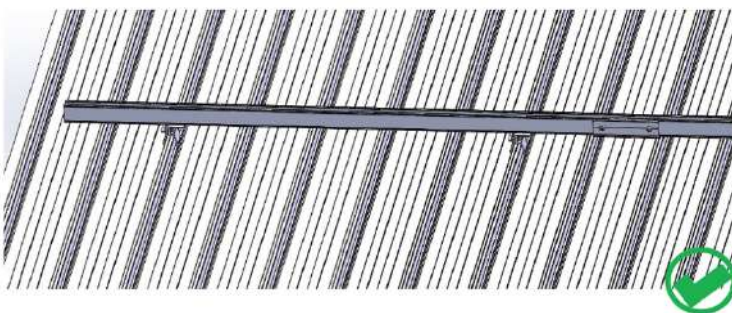

Mid and End Clamp Installation:

Mid and End Clamp Installation

Step 1: Place the first PV Module on the rail according to your plan and fix it in place using an End Clamp.

Fasten lightly as shown in the image.

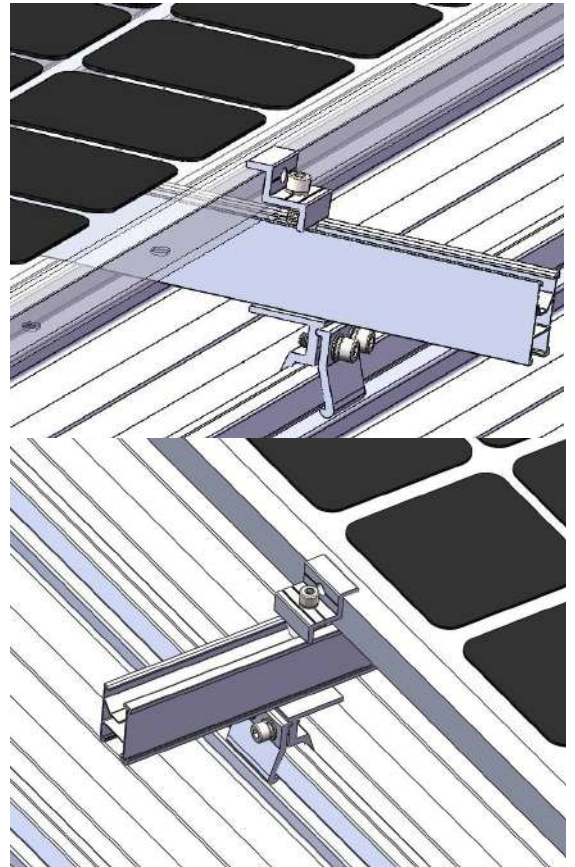

Step 2: Slightly lift the PV Module and slide Mid Clamps and Earthing Clips into position. The teeth on Earthing Clip will automatically align when the Mid Clamp is properly installed as seen in the image.

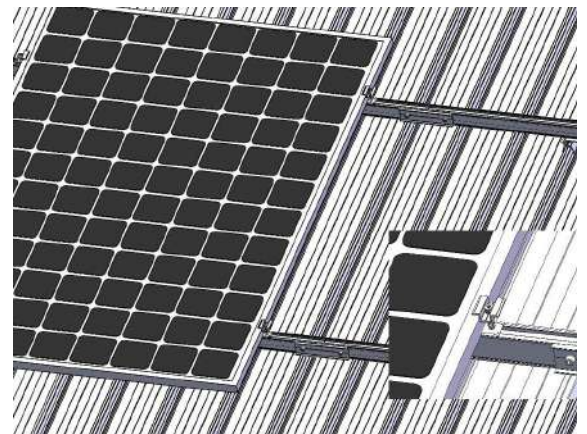

Step 3: Place the next PV Module into the other side of the Mid Clamp and Earthing Clip as shown in the image.

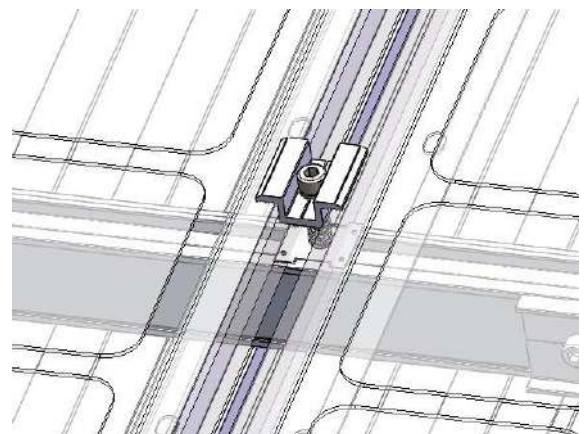

Notes:

- When fastening the bolts, the bonding pins on the mid and end clamps pierce the anodized layer of the PV module, enabling electrical conductivity, as shown in the image.
- During mid clamp installation, ensure that the earthing clip is positioned between the panel and the rail. This ensures that, once the bolts are fastened, the earthing clip pierces the anodized layer of both the rail and the panel simultaneously, achieving proper conductivity.
- The two holes on the end clamp allow for switching between two panel thicknesses—30mm and 35mm, as shown in the image.

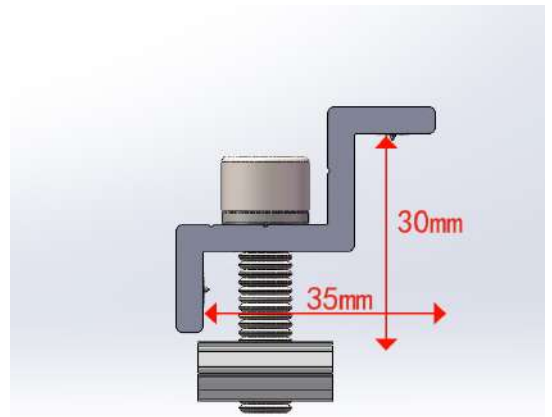
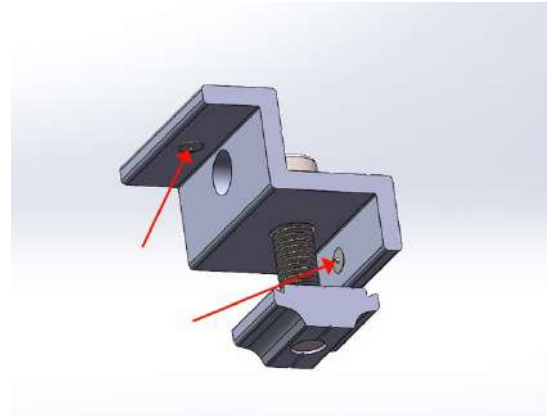
**Important Notes:**

- Ensure PV module frames are fully pressed against end and mid clamps, as well as earthing clips. Visually check that earthing clips are correctly positioned. **Earthing clips are for single use only.**
- Fasten bolts with a torque of 16-20 N·m only once the PV module position is finalized. (Slightly tighten bolts to hold modules in place before final adjustment).
- Replace earthing clips when replacing defective PV modules.
- When removing defective PV modules, ensure enough earthing clips remain to maintain continuity with the rail. Install earthing clips under end clamps if needed.
- For arrays with more than two rows of rails, use the same layout and quantity of earthing clips as for two rows.

Mini-Rail Installation

Determine the installation position of the first Mini-Rail according to the installation plan.

Secure the clamp onto the rib of the metal sheet by fastening the 2 bolts, as shown in the figure below.

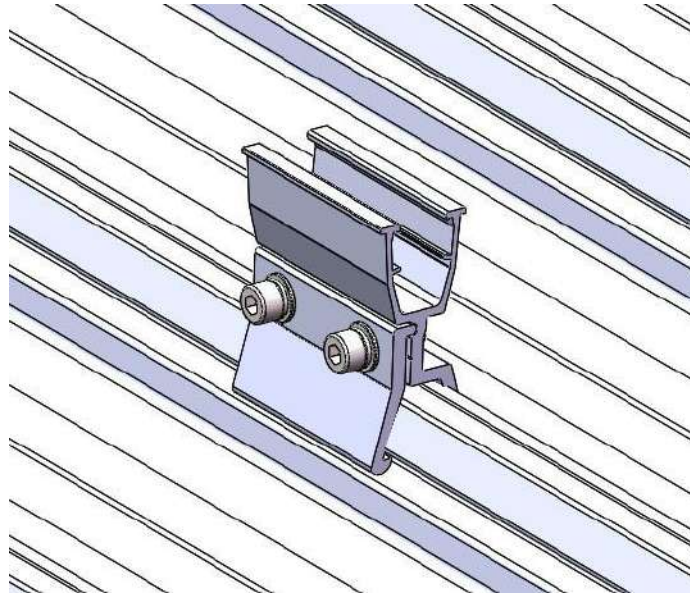

Fix the Mini rails onto the roof in a straight line as shown below;

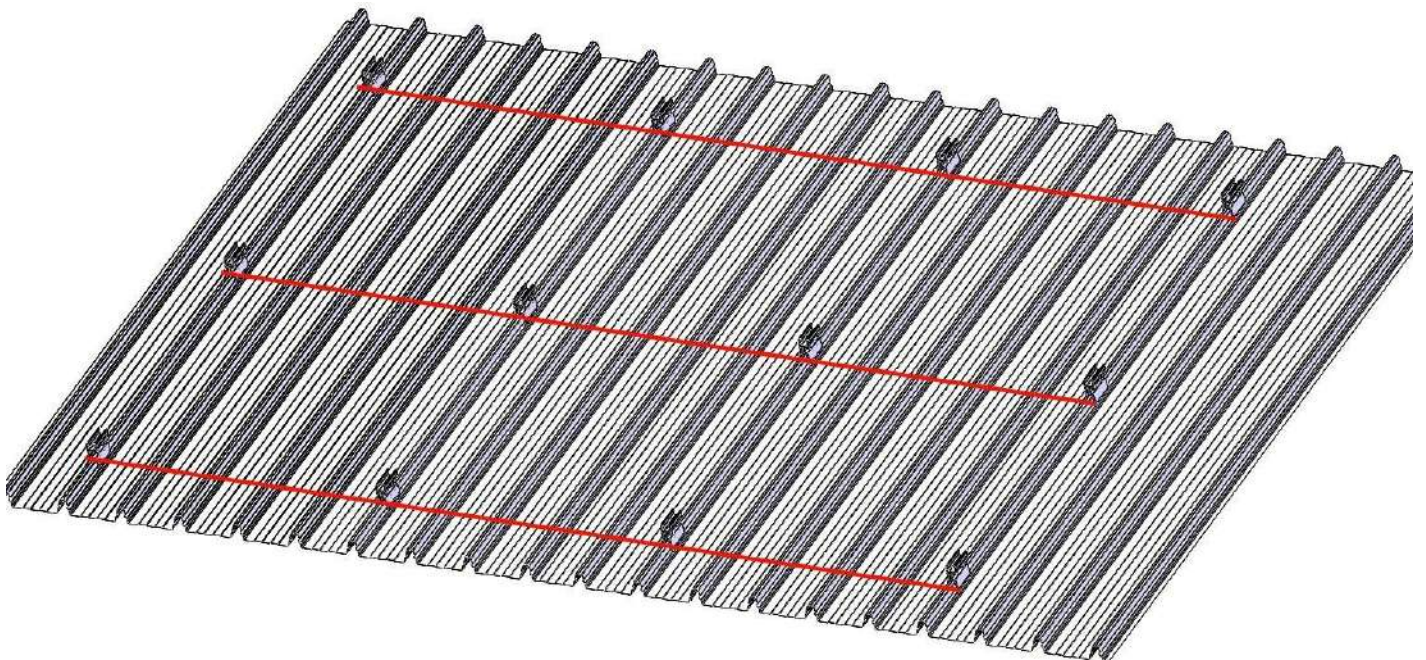

Solar Panel Installation

Place the end clamps onto the mini rails.

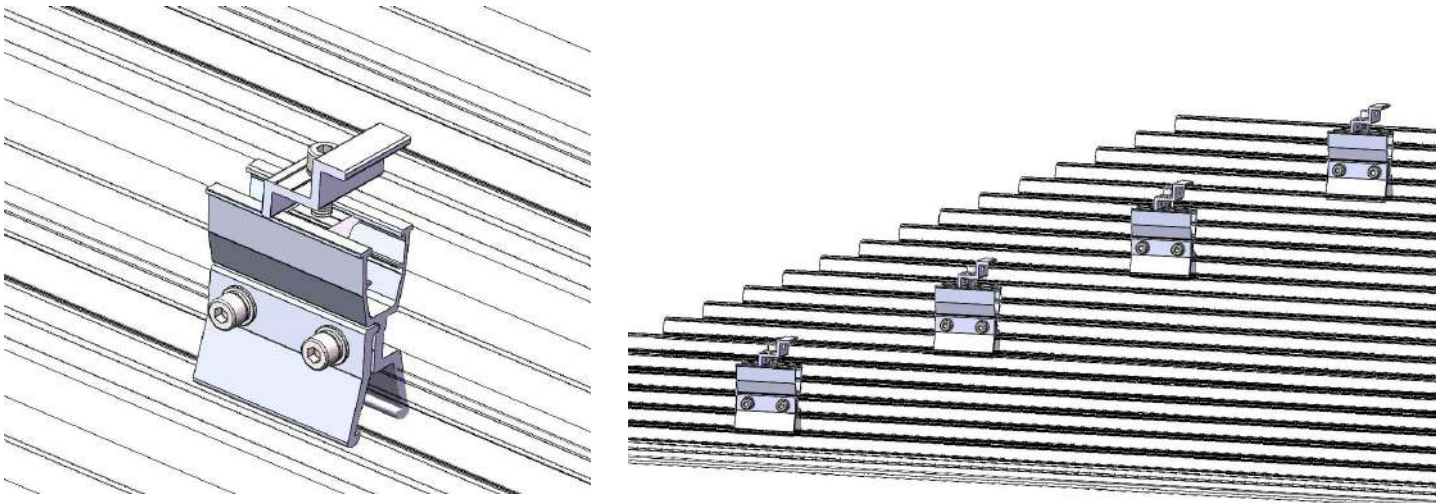

Lay the modules onto the Mini-Rails and fasten the end clamps.

When the bolts on the end clamps are fastened, the bonding pins pierce the anodizing film on the surface of the PV module, thereby achieving conductivity between the modules.

The recommended torque of the end clamp bolts is 16-20N.m.

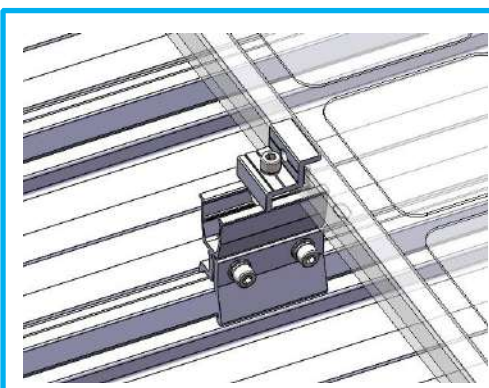
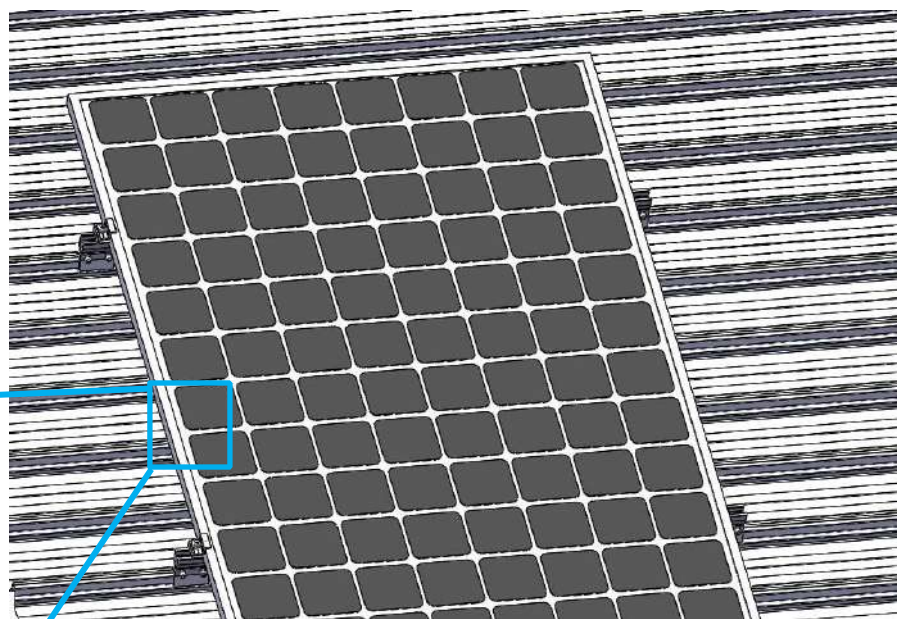

Lift the PV Module slightly and slide the Mid Clamps and Earthing Clips into position. The teeth on Earthing Clip will Automatically align when the Mid Clamp is properly installed as shown. Place another panel on to the mini rails and push up against the Mid Clamp and into position before fastening the bolt.

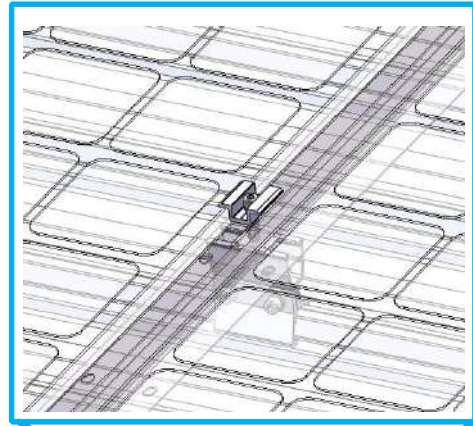
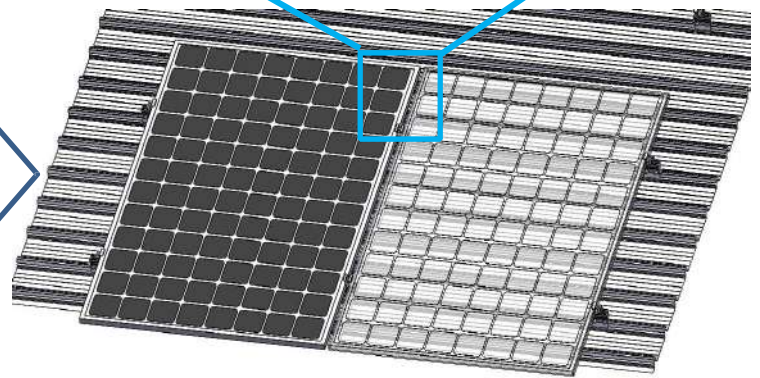
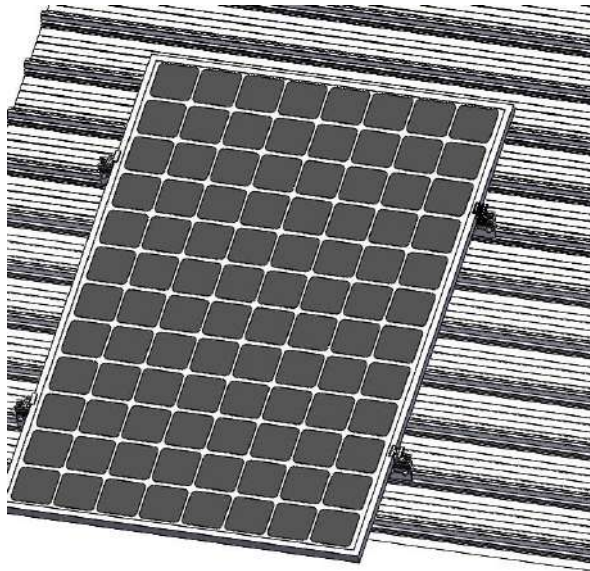

Note:

When fixing the Mid clamps and End clamps onto the Roof clamp, slide the rail-nut bolt set into the rail from the sides.

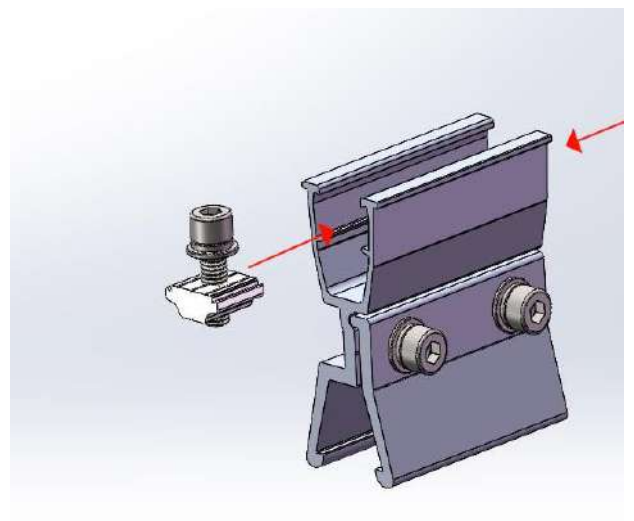

Grounding Lug Installation

Installation Requirement:

Install one grounding lug per rail row.

Use a recommended fastening torque of 16-20 N·m for M8x25 bolts.

Cable Connection: After fixing the grounding lug to the rails, strip the earthing cable (max size: 35 mm²). Insert the conductor into the channel and tighten the M8x20 bolt to 8-12 N·m to secure the cable.

Note: Check the electrical resistance between the rail and earthing cable conductor to ensure proper bonding.

Grounding Lug Installation Options:

Option 1:

Mount the grounding lug in the top channel of the rail.

Option 2:

Mount the grounding lug in the top channel of the rail, just below the PV module. This option accommodates PV modules up to 30 mm in height.

Option 3:

Mount the grounding lug in the side channel of the rail.

